

INSTRUCTION MANUAL

**YAESU FC-707
SOMMERKAMP FC-767**

YAESU FC-707 ANTENNA COUPLER



GENERAL

The FC-707 is an ultra-compact antenna tuner for the FT-707 transceiver. Designed for operation on the 80 through 10 meter amateur bands, the FC-707 will provide a 50 ohm load to the transceiver when the feedpoint impedance of the antenna system is within the range 10 ohms to 250 ohms.

The FC-707 includes a built-in SWR and power meter, calibrated in 15 watt and 150 watt scales. Also included is a 50 ohm dummy load, which may be selected instead of the antenna for preliminary coupler adjustments. A THRU position of the bandswitch also allows the antenna to be connected directly to the transceiver, bypassing the tuner.

High-quality low-loss components are used throughout the FC-707. The matching function it performs means your transmitter will always "see" the resistive termination it was designed for. The inherent selectivity of the FC-707 matching circuitry helps attenuate harmonics, too, thus reducing harmonic-related TVI or out-of-band emissions.

We recommend that you read this manual in its entirety, so as to derive maximum benefit from your new FC-707.

SPECIFICATIONS

Frequency coverage:

80m	3.5–4.0 MHz
40m	7.0–7.5 MHz
30m	10.0–10.5 MHz
20m	14.0–14.5 MHz
17m	18.0–18.5 MHz
15m	21.0–21.5 MHz
12m	24.5–25.0 MHz
10m	28.0–29.7 MHz

Input impedance:

50 ohms

Max. variation in load impedance:

10–250 ohms

Maximum transmitter power:

150 W RF @ 50 ohms

Power meter calibration scales:

15 W, 150 W

Insertion loss:

0.5 dB max.

Rear panel antenna connection:

UHF type connector

Dimensions:

238(W) x 55(H) x 180(D) mm

Weight:

2.0 kg

SWR calibration:

To 5:1 SWR



FP-707/FT-707/FC-707/FV-707DM/YM-35

FRONT PANEL CONTROLS AND SWITCHES

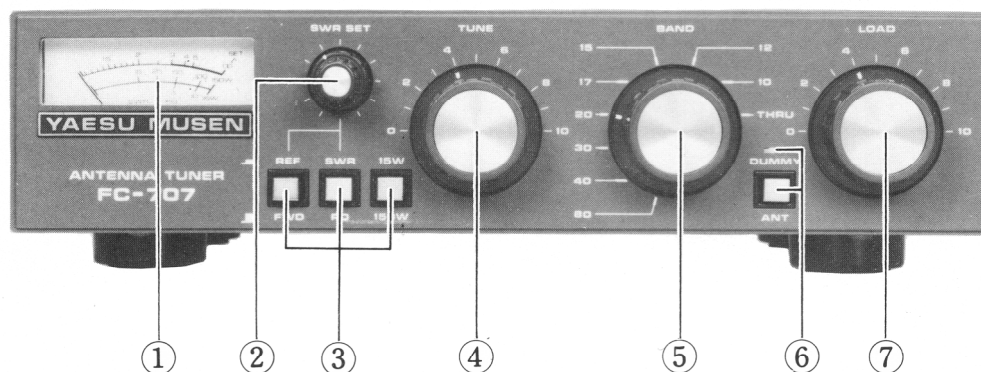

(1) METER

The meter provides indication of the SWR or power level.

(2) SWR SET

This control sets the sensitivity of the SWR meter.

(3) FUNCTION SWITCHES

REF/FWD This switch selects forward or reflected power indication on the meter.

SWR/PO This switch selects indication of the SWR or power output on the meter.

15W/150W This switch selects indication of the output power level scales: 15 watts maximum or 150 watts maximum.

(4) TUNE

The TUNE control drives a variable capacitor which provides capacitive adjustment of the coupling between the transmitter and the impedance

established by the BAND switch and LOAD control. The TUNE and LOAD controls are adjusted for minimum SWR.

(5) BAND

The BAND switch selects the tap on the main tuning inductor for the antenna coupler appropriate for the band in use.

(6) DUMMY/ANT

This switch selects between antenna matching or connection to the 50 ohm dummy load. When the built-in dummy load is selected, the antenna coupler tuning controls are still in the line, so preliminary adjustment of the coupler can be accomplished.

(7) LOAD

The LOAD control drives a variable capacitor which adjusts the coupling between the antenna feedline and the main tuning inductor.

REAR APRON

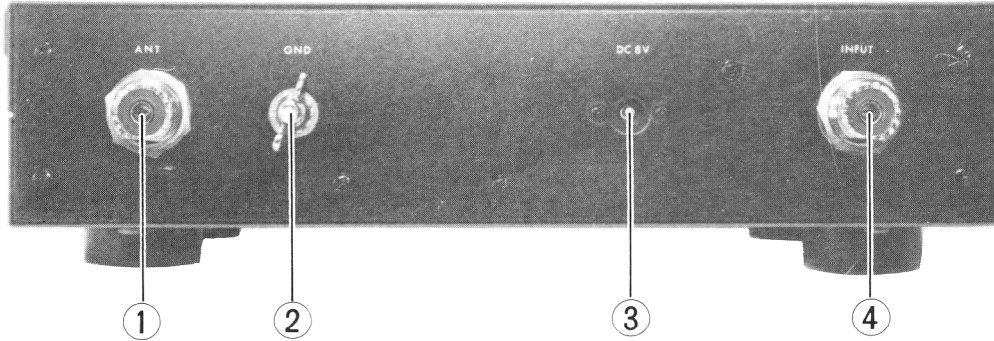

(1) ANT

This is a standard UHF connector for the antenna feedline.

(2) GND

Connect a good earth ground at this point.

(3) DC 8V

The DC8V line from the FT-707 transceiver should

be connected here, for driving the meter lamp on the front panel of the FC-707.

(4) INPUT

Connect the line to the FT-707 transceiver at this point.

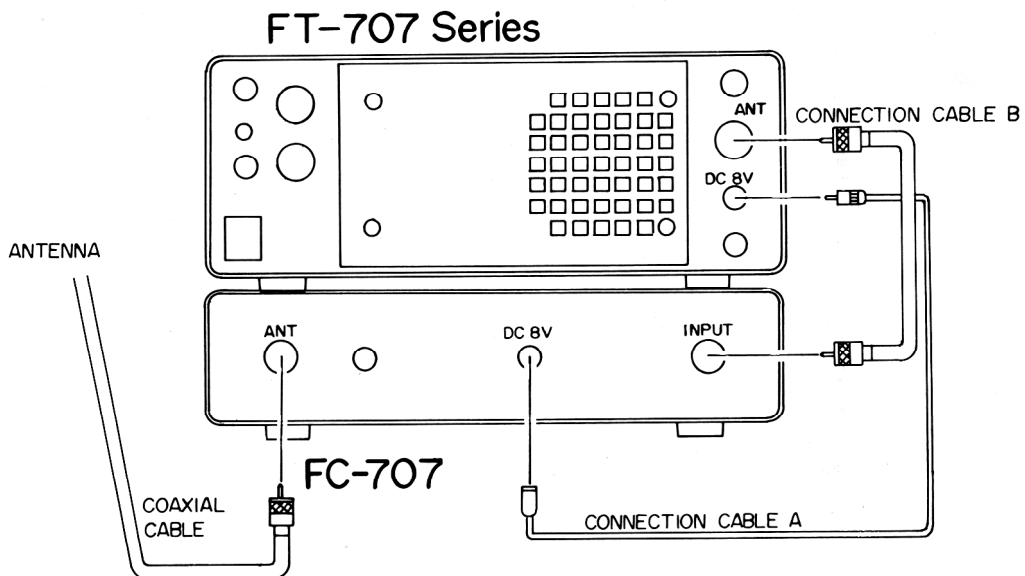

INSTALLATION

Connect the antenna to the rear panel ANT jack, and connect a 50 ohm coaxial cable between the FT-707 and the FC-707. Connect the DC cable between the DC8V jacks of the FC-707 and the FT-707. Connect a good earth ground to the GND terminal on the rear of the antenna coupler, using a heavy, braided wire less than 10 feet long for connection to the station ground buss.

When using a transceiver other than the FT-707, be absolutely certain to observe the proper polarity and level of the voltage applied to the rear panel DC8V jack. Do not exceed 8 volts DC, nor apply AC power of any kind, to this jack. Our warranty does not cover damage caused by improper power connections to this equipment.

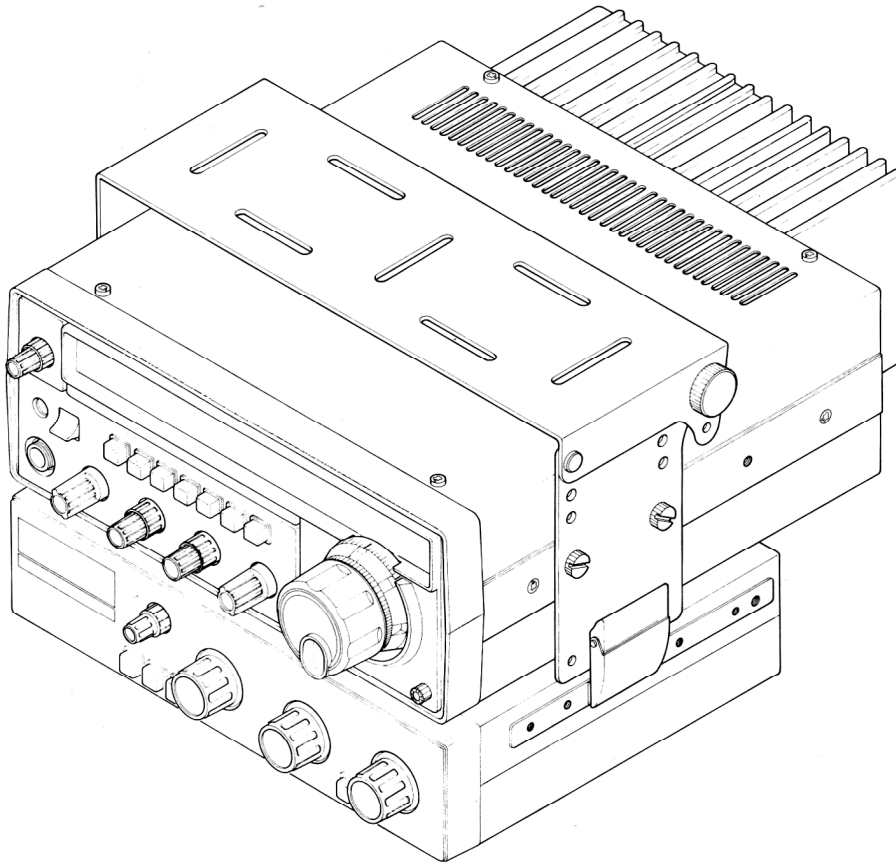

FT-707/FC-707/MMB-2

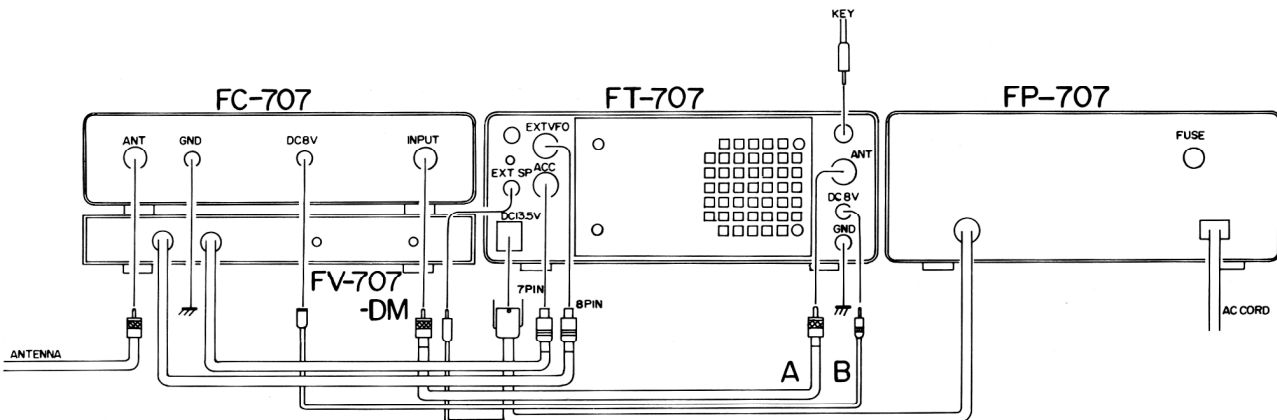

ANTENNA MATCHING PROCEDURE

IT IS STRONGLY RECOMMENDED THAT THE FOLLOWING SECTION BE READ IN ITS ENTIRETY BEFORE ANY MATCHING OF ANTENNAS IS ATTEMPTED. WHILE A STRAIGHT-FORWARD PROCEDURE, ANTENNA MATCHING WITH A COUPLER SUCH AS THE FC-707 INVOLVES A LOGICAL PROGRESSION OF STEPS, AND FAMILIARITY WITH THE TOTALITY OF THE FOLLOWING SECTION WILL CLARIFY THE PROCEDURE IMMENSELY.

To summarize the procedure that is followed in using the FC-707 antenna coupler to match a feed-line to the transmitter, the following process takes place:

- 1) The proper inductance is chosen using the Band switch.
 - 2) The LOAD and TUNE controls are adjusted to secure a minimum SWR. These two controls should be adjusted one at a time, so as to avoid confusion as to the effect of any particular adjustment. A typical procedure to follow would be to apply power, adjust the TUNE control for minimum SWR, then adjust the LOAD direction either to the right or left. Once the LOAD control has been changed, the TUNE control should again be adjusted for minimum SWR; if this procedure improves the SWR, it should be continued by further moving the LOAD control in the same direction, but if the initial change in the LOAD control worsens the SWR, one should try moving the LOAD control in the opposite direction. It will be clear to the operator when the LOAD control is being adjusted in the right direction.
- (1) Set up the FT-707 or other transceiver for normal operation. Set the DUMMY/ANT switch to DUMMY to select the built-in dummy load. Reduce the drive control on the transceiver to the minimum, and place the transmitter in the "standby" condition for the moment.
 - (2) Place the BAND, LOAD, and TUNE controls in the positions shown in Figure 1 for the frequency at which the antenna is to be matched. Put the SELECT switches in the FWD, SWR, and 150W positions. Set the SWR SET knob to the 12:00 position.
 - (3) It is desirable to make preliminary matching adjustments with as little transmitter power as possible. Place the FT-707 in the "transmit" condition, and slowly advance the drive until deflection of the meter needle is observed. Adjust the SWR SET control to align the meter needle with the SET marking on the meter scale. Now switch the FWD/REV switch to REV for accurate reading of the SWR.
 - (4) Adjust the TUNE control for a minimum reading of the SWR. If necessary, adjust the SWR SET control and/or transmitter power to ensure proper calibration (be certain to check the SWR meter sensitivity with the FWD/REV switch in the FWD position, then switch back to REV). Once the "dip" has been found using the TUNE control, move the LOAD control a small amount in either direction, left or right. Adjust the TUNE control for a "dip" again, and if the SWR is lowered, move the LOAD control slightly more in the same direction. Again "dip" the TUNE control, and continue this procedure until no further improvement is noted. If the initial direction of adjustment of the LOAD control makes the SWR higher, move the control an equal direction in the opposite direction from the starting point, and "dip" the TUNE control. Remember to recheck the calibration of the SWR meter to avoid misleading readings.

The reader is referred to Figure 1, where the approximate positions of the BAND, LOAD, and TUNE controls are shown for matching to a 50 ohm load. The internal dummy load is extremely useful in presetting controls with a known impedance. The antenna may then be selected, with final tuning taking only a few seconds.

- (5) Once the initial procedure has been followed to yield a near-perfect match, the transmitter may be adjusted for full power, and the FC-707 LOAD and TUNE controls may be adjusted to yield zero deflection of the SWR meter. When the SWR meter is not calibrated with the SWR SET control, it will not accurately read the SWR, but it will indicate minimum reflected power. Do not exceed the maximum key-down time stipulated for your transmitter.
- (6) Now set the DUMMY/ANT switch to ANT. Following the technique described above, you may tune your antenna system so as to secure minimum SWR. Always begin tuning at low power, to avoid damage to transceiver or coupler components caused by unknown impedances.

	BAND	TUNE	LOAD
3.5 MHz	80	4.5	7.0
4.0 MHz	80	5.5	7.5
7.0 MHz	40	6.0	7.5
7.5 MHz	40	6.0	8.0
10.0 MHz	30	6.5	8.0
10.5 MHz	30	7.0	8.5
14.0 MHz	20	6.5	8.5
14.5 MHz	20	7.0	8.5
18.0 MHz	17	7.5	9.0
18.5 MHz	17	7.5	9.0
21.0 MHz	15	7.5	9.0
21.5 MHz	15	8.0	9.0
24.5 MHz	12	7.0	9.0
25.0 MHz	12	7.0	9.0
28.0 MHz	10	7.0	8.5
29.7 MHz	10	7.0	9.0

Figure 1

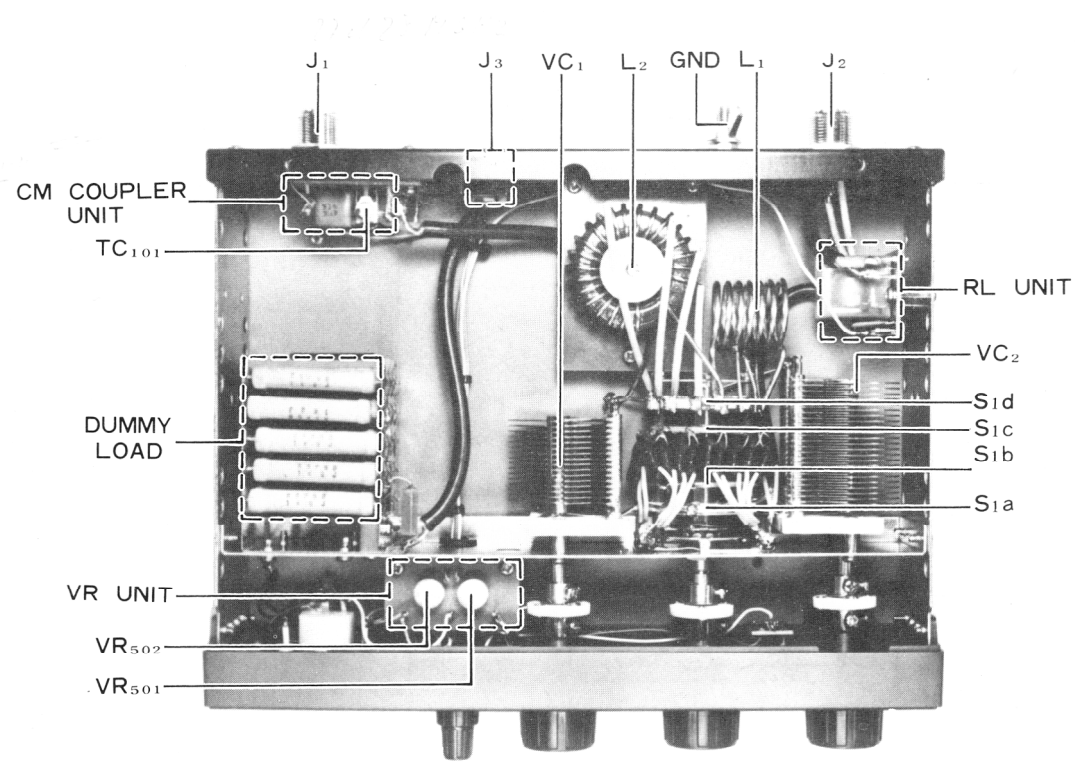

Top View

NOTES ON ANTENNA MATCHING

- (1) It is very important that the maximum time limits during tune-up conditions for the transmitter are not exceeded. This is particularly important when the transmitter is being used at full power.
- (2) It should be noted that any matching performed by the FC-707 in the shack will have no effect on the losses due to SWR on the coaxial line between the FC-707 coupler and the antenna. The operator should consult one of the popular antenna handbooks to determine whether or not matching between the coaxial line and the antenna must be performed at the antenna. For example, a 100-foot length of RG8A/U coax typically has a loss (with 1:1 SWR between it and antenna) of less than 1 dB at 21 MHz. If this line is operated with a 3:1 SWR due to a low or high antenna impedance, the loss due to SWR will increase roughly 0.5 dB, an imperceptible degradation as compared to the 1:1 condition. In this case, attempts to reduce the 3:1 SWR at the antenna end would serve no useful

purpose as far as reducing losses in the coax, through matching with the FC-707 would improve the impedance presented to the transmitter output circuitry. However, if a 500-foot length of the above coax were used instead of only 100 feet, somewhat more than 1 dB of loss would occur in the coax due to the 3:1 SWR, possibly justifying further matching attempts at the antenna.

- (3) When using a transceiver such as the FT-707 which has protection for the output transistors against high SWR, it can be seen that the matching action of the FC-707 will ensure that a 50 ohm load is presented to the output circuitry, thus ensuring full transmitter power.
- (4) It may be useful for the operator to record in a notebook the proper TUNE and LOAD positions for a particular antenna for quick reference. Alternatively, appropriate labels may be fabricated and applied to the FC-707 front panel showing the proper positions of the TUNE and LOAD controls.

